

Advantage™ PFA Vessels for Aggressive Aqueous Chemical Filtration

Parker Advantage PFA series fluoropolymer vessels are designed for the most challenging semiconductor and microelectronics chemical filtration applications. These high purity vessels accommodate all standard 2-222 single-open-end Advantage membrane cartridges. These vessels are available in 4-in, 10-in and 20-in lengths with vent, drain and sample port. Several inlet/outlet configurations are available.

Applications

UHP Water

- Ozonated
- Cold
- Hot

UHP Chemicals

- Acids
- Solvents
- Photoresists
- Alkalines
- Developers
- Mixed Acids
- Strippers

Equipment

- Point-Of-Use Tools
- Chemical Delivery System
- Cleaning
- Etching
- Photolithography
- Wet Benches



Features and Benefits

- Advantage PFA vessels are available in three sizes to accommodate most common cartridge lengths.
- The PFA corrosion-resistant vessels meet industry standards for fatigue resistance, burst strength and negligible extractables.
- Nine inlet/outlet connection configurations are available for versatile installation capability.
- PFA series vessels are ideal for Parker Advantage AF and AF+ pleated membrane cartridges to provide a 100% fluoropolymer filtration system.
- Three-piece construction with PVDF locking ring for ease of filter element changeout.
- Non-rotating bowl with locking ring ensures leakproof torsion-free sealing.
- Installation brackets are available in PTFE and Teflon coated 304 stainless steel.
- Designed for clean room applications.
- Preflushed with UHP water for high purity contact surface.

Process Filtration Division



Specifications

Materials of Construction:

- Head and bowl: PFA (440 HP)
- Locking ring: PVDF (non-wetted)
- Head-to-bowl standard o-ring: 2-344 PFA encapsulated Viton
Options: Various-refer to ordering information.

Dimensions:

- Vessels: Refer to drawing
- Inlet/Outlet connections:
NPTF: 3/4 in, 1/2 in
Parflare: 1/2 in, 3/4 in, 1 in
Tube: 3/4 in, 1 in
Butt Weld pipe: 3/4 in, 1 in
- Vent and sample port:
NPTF: 1/4 in
Parflare: 1/4 in
Butt Weld Pipe: 1/4 in
- Drain:
NPTF: 1/4 in
Parflare: 1/4 in, 3/8 in

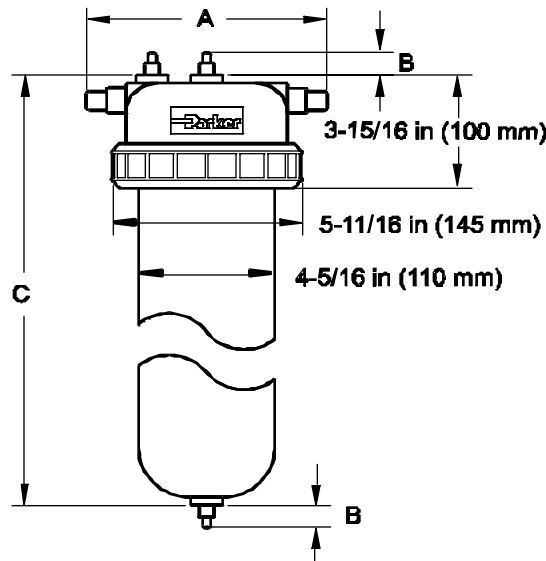

Vessel Dimensions:

- A
Parflare=7 7/8 in (200 mm)
Butt Weld Pipe=10 in (254 mm)
NPTF=7 1/16 in (179 mm)
Tube=10 in (254 mm)
- B
Parflare=1 in (25.4 mm)
Butt Weld Pipe=1 in (25.4 mm)
NPTF=0 in
Tube=1 in (25.4 mm)
- C
4 in Vessel=8 7/16 in (214 mm)
10 in Vessel=13 9/16 in (345 mm)
20 in Vessel=23 7/16 in (595 mm)

Recommended Operating Conditions:

- Maximum operating pressure and temperature:
Parflare; NPTF; Butt Weld Pipe:
150 psig (10.3 bar) @ 77°F (25°C)
60 psig (4.1 bar) @ 221°F (105°C)
Tube:
90 psig (6.2 bar) @ 77°F (25°C)
35 psig (2.4 bar) @ 221°F (105°C)

Maximum recommended flow rate:

- 3 gpm (0.8 lpm) for PFA 04
- 6 gpm for (1.6 lpm) PFA10
- 12 gpm (3.2 lpm) for PFA20

Accepts Industry Standard Cartridge Sizes:

- 2-1/2 in (64 mm) to 3-1/4 in (83 mm) OD x 1 in (26 mm) ID x 4 in (102 mm), 10 in (254 mm) or 20 in (254 mm) long with double 2-222 O-ring.
- Parker Advantage membrane cartridges:
AF: 2.5 in (64 mm) dia
AF+: 3.25 in (83 mm) dia
PF: 2.7 in (69 mm) dia

Ordering Information

PFA	10	F	08	F	02	F	02	T
Material of Construction	Bowl Length	Inlet/Outlet Configuration	Inlet/Outlet Size	Drain configuration	Drain Size	Vent/Sample Port Configuration	Vent/Sample Port Size	Seal Material
PFA = PFA 440HP head and bowl with PVDF locking ring	04 = 4 in** 10 = 10 in 20 = 20 in**	F= Parflare N = NPTF T = Tube W = Butt Weld Pipe	05 = 1/2 in** 08 = 3/4 in 10 = 1 in	B = Blank F= Parflare N= NPTF	02= 1/4 in 03= 3/8 in	B = Blank F= Parflare N= NPTF W = Butt Weld Pipe	02= 1/4 in	D = CR 570 K = Kalrez 4079 L = Kalrez 8201 P= Parflare T = PFA/Viton* V= Viton* X= None

** Consult Factory for Availability

* Trademark of E. I. duPont de Nemours & Co.

Fischer-Robertson, Inc

3890 Symmes Road

Hamilton, Ohio 45015

p: 513-860-3445

f: 513-860-4744

sales@fischer-robertson.com

www.fischer-robertson.com